



HEAD OFFICE
CHARLTON BUILDINGS
LOWER BRISTOL ROAD
BATH BA2 3EA

Tel: (01225) 315449
Parts: (01225) 447659

E-mail: morris.minor@ukonline.co.uk
Web site: www.morrisminor.org.uk

Notice to our customers
To avoid confusion please note that Morris Minor Centre (Bath) Limited
which has moved from Bath is not part of our organisation.

Cars for sale

We have a selection of fundamentally superior rust free Minors for sale many of these in superb original condition.

Restoration

Our unique Durable Car programme allows average Morris Minor owners to forward plan a logical restoration programme

over a few years, based on their motoring budget.

We have implemented various updates in the recent past:

- 1300 engines
- Suspension and Braking systems
- 5 speed gearboxes etc

For further details on these and many more please see our information brochure.

Insurance Logical cover for your Minor, whether it's worth £300 or £3000.

Parts

Our new fully illustrated **Mail Order Catalogue** shows all standard Minor parts available and the Series 3 specifications in full colour.

ONLY £6 including postage.   

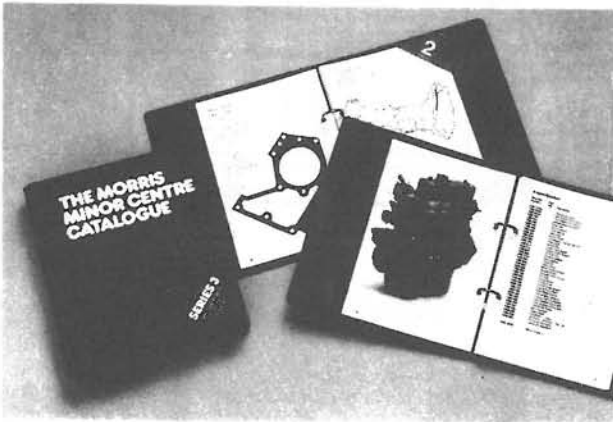

THE MORRIS MINOR

Where to look for rust.

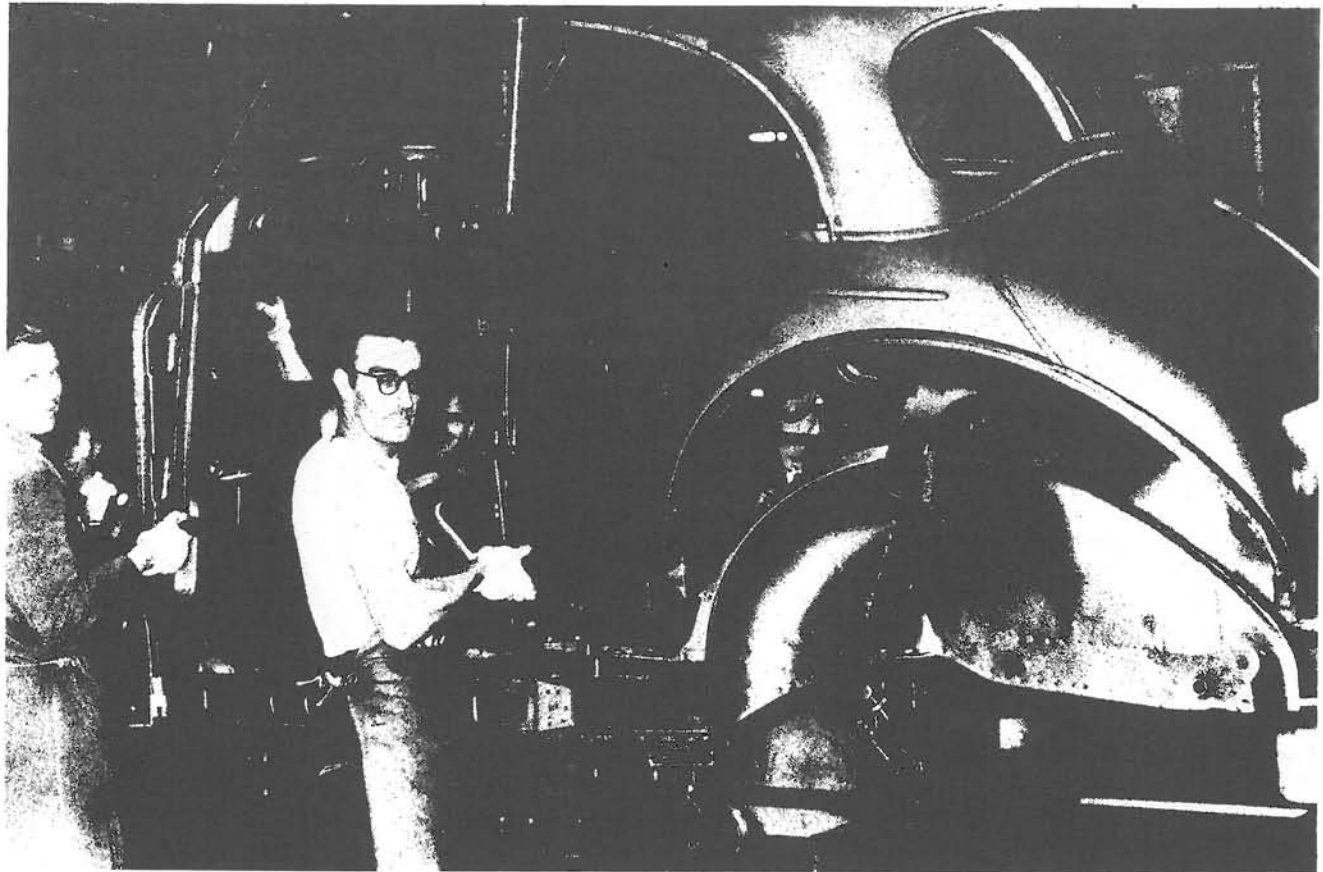

Introduction

This guide is designed to help Owners and Buyers to understand the fundamental causes of Terminal Structural Rust in Morris Minor Cars. Ninety percent of them are suffering from Internal Corrosion in the lower bodyshell/chassis, and over the years inappropriate cosmetic MOT repair work is carried out in the motor trade, and by owners, in the belief that covering up the problem will solve it.

This short term attitude is largely because the United Kingdom annual Ministry of Transport Test (the MOT) is very limited when it comes to testing structural strength. The Examiner is only allowed to use a screwdriver to poke around the areas close to important suspension mounting points. As a consequence the careful application of a piece of tin, pot rivetted over a hole and then carefully undersealed, will nine times out of ten be passed by the MOT station.

Compared with 'modern' cars constructed from thin stressed panels, (which reveal their structural weaknesses clearly within 5 to 8 years) a Morris Minor is built like a tank and normally takes 10 to 15 years to develop serious internal rust, so it is important that they should all be examined carefully for long term corrosion, irrespective of their mechanical efficiency or pedigree – i.e. one lady owner from new only 20,000 warranted miles etc.

Morris Minors have very durable mechanical specifications, which, with proper servicing, remain efficient after having travelled 200,000 miles on the road. So the fact that they are reliable is no guide to their structural integrity.

To illustrate this I would like to tell you a short story. About eight years ago an old white haired lady, in a little cottage with roses around the front door, sold me her 1962 saloon that had only travelled 5,000 authenticated miles from new.

Visually the car looked good – original wings, doors, mainly original paintwork and beautiful interior trim, it drove well. Underneath the car had been re-undersealed, looked original and I didn't examine it carefully – which was fatal because when the car was brought back to Bath it was discovered that the chassis/underbody was largely fibre glass and filler carefully applied to deceive the eye. The car was so rusty that it would need £2,000 of structural re-instatement work to get it into good long term order. Feeling a bit fed up, I telephoned the old lady and asked her who had been looking after her car. The reply was "my sons who have a coachworks. I asked them to make Henry (The Minor) look his best before passing him on to his next home". The lesson of this tale is clear. When buying an old car, don't get too carried away by what you want to believe.

When examining a Minor, it is important to use your eyes and particularly ears. The sound of pressed steel sections can tell one a lot about condition. Use a light hammer to firmly tap the hollow box sections on the underbody/chassis, and listen for the clear ring of sound metal, the dull thud of poor repairs and the sound of eggs breaking when it is rotten. This, together with a knowledge of the illustrations, should allow you to avoid the worst pitfalls!

Charles Ware
Managing Director

Lower Bodyshell (Chassis)

All but a handful of Minors are suffering internal rust in the hollow structure box and double skinned sections that make up the basic strength of the lower bodyshell.

Years of condensation forming inside these hollow areas, and then never drying out (because of the damp climate of the British Isles), is the principal cause of internal rust. As it develops the rust eats through the steel pressings from the inside to the outside surfaces.

When holes appear they are patched and covered over in order to get an MOT. This short term approach is inappropriate because the internal corrosion continues to develop and eventually destroys the structural integrity of the car.

'MOT' Panels

The quality of these vary, depending on the reputation of the garage. At worst, we have found the following non structural materials used to repair vital safety anchorage points:-

Chinese 'Take Away' food cans, Oxo tins, plaster, clay and concrete in the chassis legs, and of course, fibreglass galore. All these items carefully disguised by underseal or similar black finishers. These cars carried long MOTs.

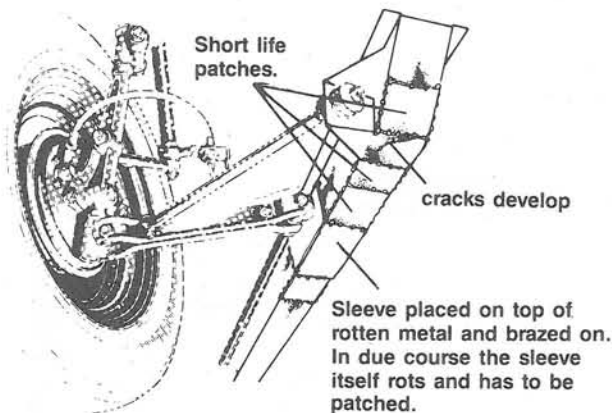

//////
These areas must be structurally sound in order to pass a realistic MOT.

■
Hollow structural pressed steel 'box' sections subject to internal rust.

○
Suspension mounting points.

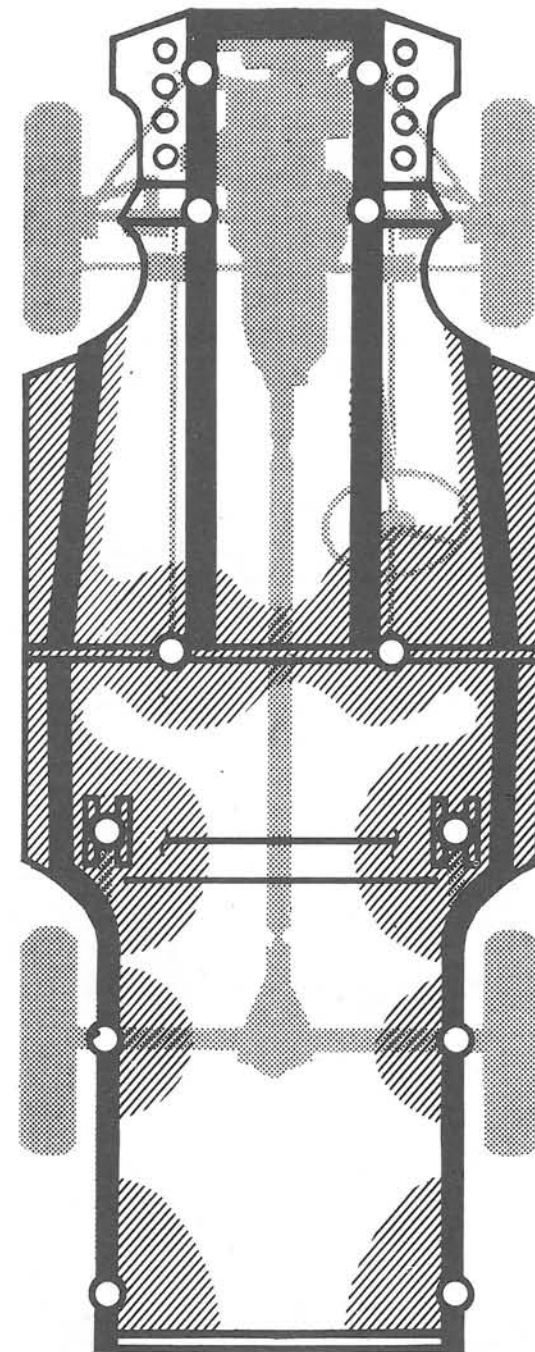

Common areas of rust.

1. Weakness and holes normally covered by the spring mount point. The rear apron also becomes weak and rusty.
2. Rear bump stops around the edges, which causes them to fall off or be patched over.
3. Seam where rear inner wing joins chassis usually weak between rear quarter panel and rear bump stop.
4. Front wheel arch rise (bottom of flich panel) behind and in front of wing.
5. Rusty bottoms of hinge and door shut posts indicates rot in Boxing plates.
6. Four door saloons rot at bottom of shut posts and two door saloons inside the panel 6A (see below).
7. Bottom front corner of rear inner wing.
8. The rear inner wing is usually packed with mud which causes long term rot above the rear spring hanger and along the seam with the bodyshell.
9. Inner quarter panels and adjacent floor areas rot at join with end of crossmember. Crossmember rots from the jacking point inwards, and when hit, metal flakes off the sides, or is holed. The flange (a vertical laminate band of metal welded to the underside of the crossmember) often opens up and forms a wavy profile underneath, letting damp into the laminates.
10. Inner and outer quarter panels and Boxing plates rot from the inside out.
11. Chassis legs and front crossmember rot from inside or as a result of damage not being repaired.
12. Tie plate on the nearside rots as a result of the radiator overflow dripping.
13. Front spring hanger. Rot develops inside the 'shoe' itself hidden by the spring. Cracks in the floor pan develop.
14. Cracks running along the area above the crossmember under the driver's seat, develop if the crossmember is weak.
15. Top of front inner wing in bump stop areas.
16. Joint between flich panel and flich extension often rots away.

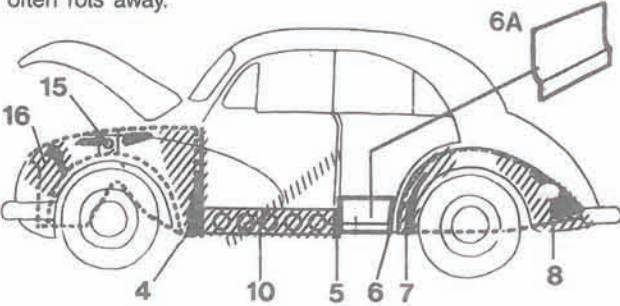

Body — Usual Weak Places.

1. Always look for 'bubbling' paint and signs of scratch marks underneath the paint, in all the areas marked, indicates repair work has been carried out.
 2. Body panels. Commonly filled and repaired areas.
- Materials used. Anything from chicken wire to old cigarette packets, newspaper and of course fibreglass. All rust comes from behind, or in the case of doors wings and bootlids, from inside out towards the surface, so it is no use filling and painting a rusty panel — except as a temporary measure.
- Different variations to the colour will indicate previous repairs if the car has been patched over the years.

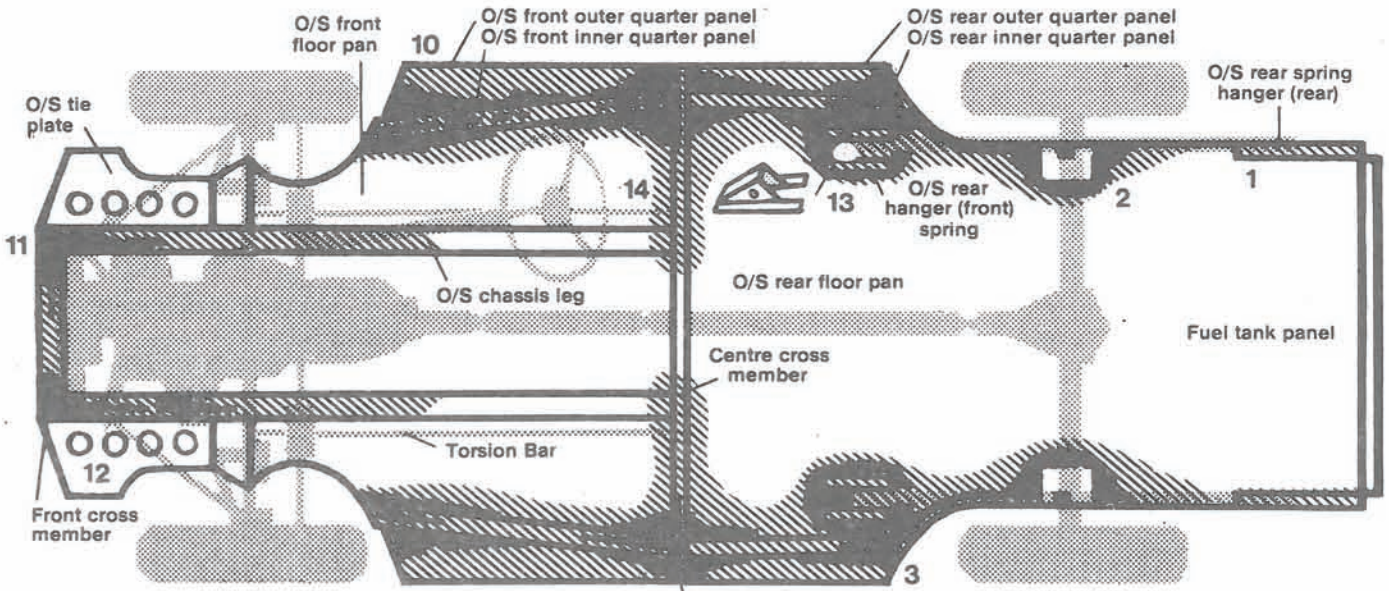
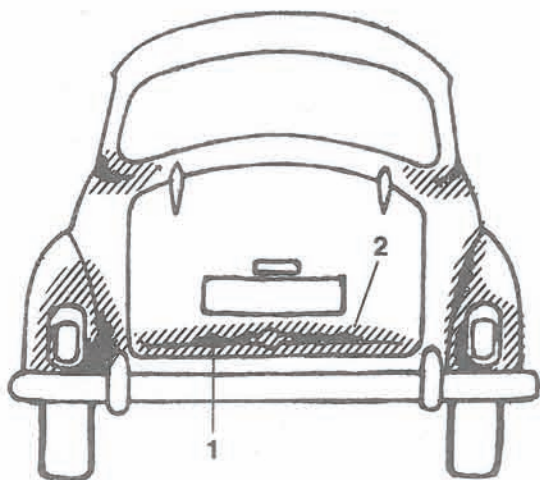
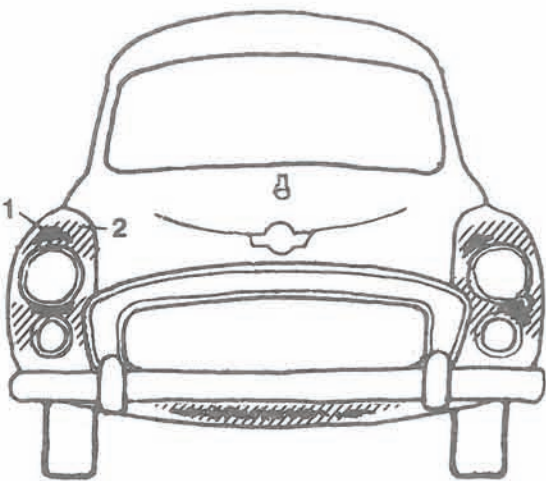

This shows a typical chassis that has not been repaired. The severe rust areas are related to hollow frame.

Bottom flange laminates open up and damp gets into the vertical laminate causing structural weakness.

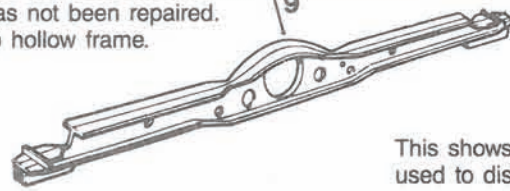

This shows where MOT patches and cover panels are used to disguise the condition of the underbody.

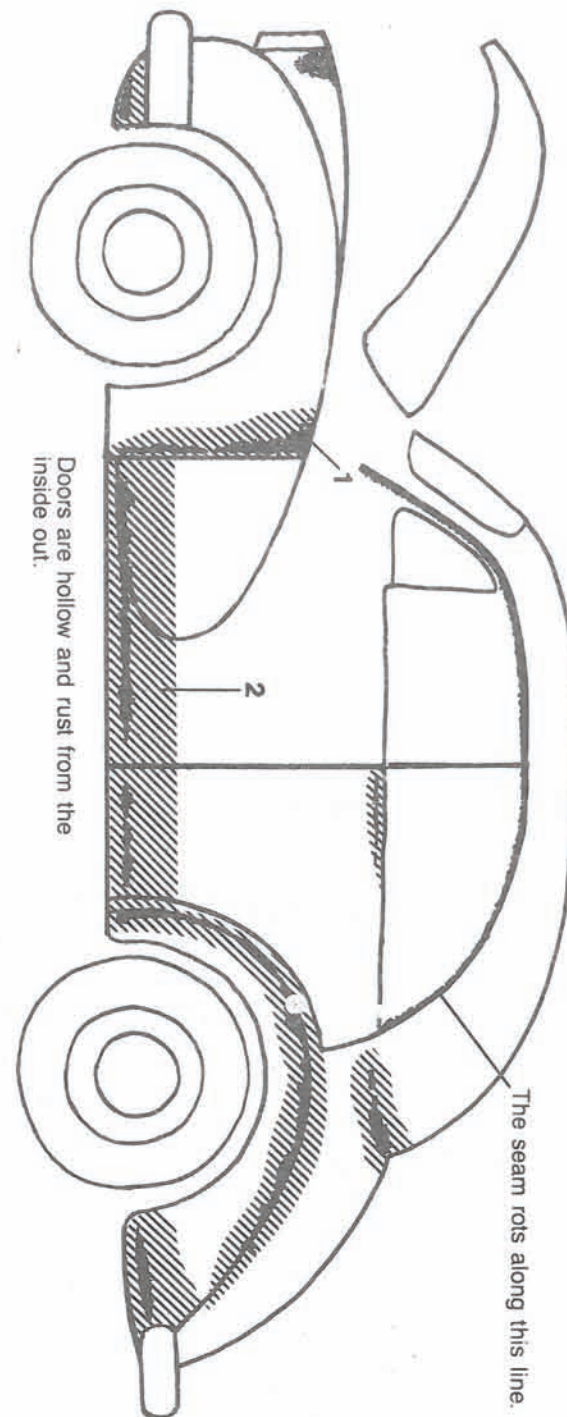
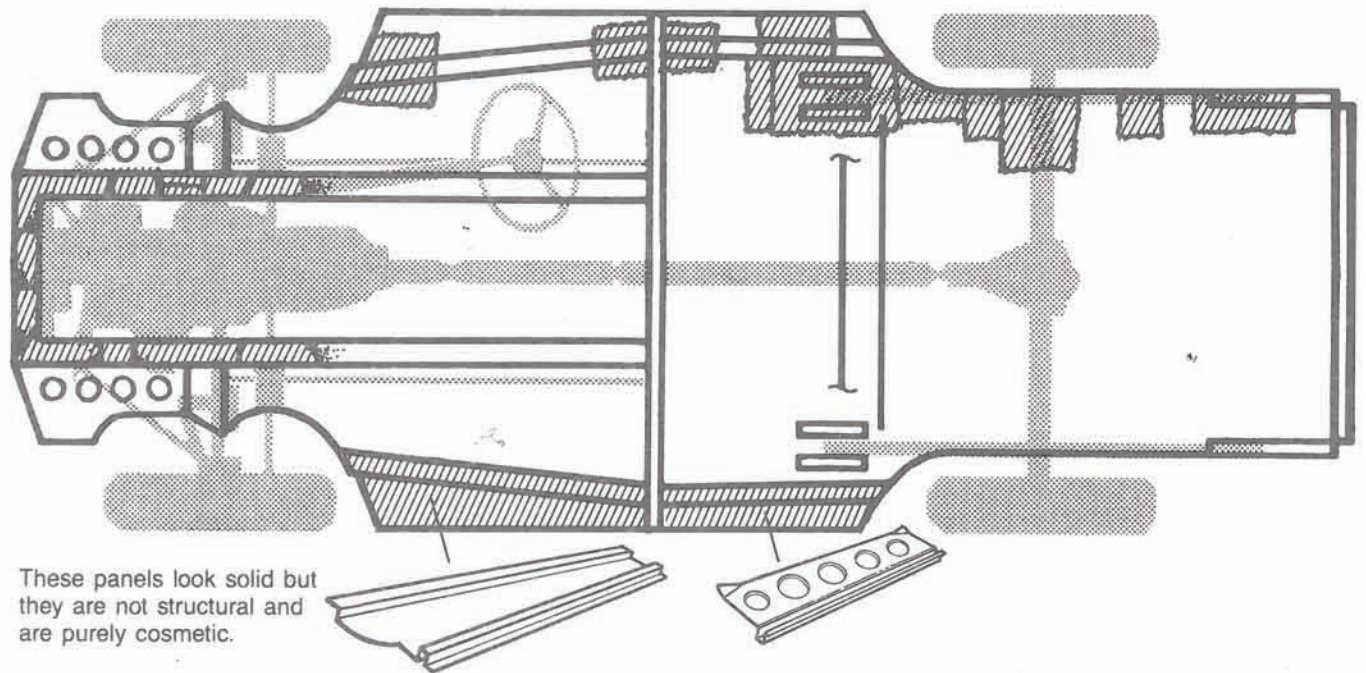

Woodwork.

1. Dark stains are the first sign of long term rot. When newly bleached and varnished, stains often look lighter than the surrounding solid timber.
2. Common rot areas: These are often filled, painted or bleached out and stained in an attempt to create an even looking surface.

